

# DRYWALL/STUCCO/PLASTER – Flat Ceilings

## Suspension Systems

Declare<sup>SM</sup>  
Living Building  
Challenge Compliant

SUSTAIN<sup>SM</sup>  
High Performance  
Sustainable  
Ceiling Systems



61%

RECYCLED  
CONTENT

Calculate LEED contribution at  
armstrongceilings.com/greengenie

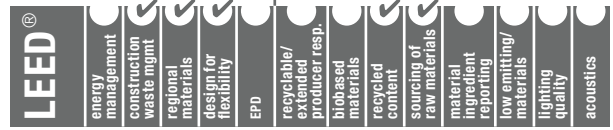

LOCATION DEPENDENT

### KEY SELECTION ATTRIBUTES

Armstrong® Drywall Grid is 3x faster than traditional track and channel framing – saving you time and labor.

- Some components available in High Recycled Content (HRC): Total Recycled Content 61%, Post-consumer 53%, Pre-consumer 8%
- Non-HRC items have 30% recycled content
- **PeakForm**® patented profile increases strength and stability for improved performance during installation
- **SuperLock**™ main beam clip is engineered for a strong, secure connection and fast, accurate alignment confirmed with an audible click; easy to remove and relocate

- HD8906IIC main beam accepts integral Impact Isolation Clips (IIC) to provide up to eight points of IIC improvement.
- **ScrewStop**™ reverse hem prevents screw spin off on 1-1/2" wide face
- Rotary-stitched during manufacture by a patented method for additional torsional strength and extra stability during installation
- HD8906 (HRC) main beams and cross tees with extra routings for Type F light fixtures
- Minimum G40 hot dipped galvanized coating, per ASTM C645; provides superior corrosion resistance
- Wind uplift construction available
- **XL**® (staked-on end detail) cross tees provide secure locked connection; fast and easy to install

- All drywall components minimum .018" steel thickness; complies with ASTM C645
- Accommodates stud, track, hat channel, wood, or other supplemental framing
- Fire Guard™ components meet broad range of UL® design assemblies (XL7936G90 is not fire rated)
- 10-Year Limited System Warranty
- 30-Year Limited Ceiling Systems Warranty
- G90 hot dipped galvanized coating is available for exterior applications (HD8906G90, XL8945PG90, XL8947PG90, XL8965G90, XL8925G90, XL7936G90)
- **SimpleCurve**™ bend to create curves as tight as 52"

### TYPICAL APPLICATIONS

- Indoor/outdoor applications
- Soffits/special transitions
- High visibility areas
- Combination drywall and acoustical panel or tile ceilings
- Barrel vaults and domes
- Wet installations (stucco/plaster)

### FIRE RESISTANCE RATING

Meets a broad range of UL design assemblies: D501, D502, G523, G524, G526, G527, G528, G529, J502, K504, L502, L508, L513, L515, L525, L526, L529, L564, P501, P506, P507, P508, P509, P510, P513, P514, P516 (XL7936G90 and SP135 are not fire rated).

NOTE: See UL Directory for details on specific designs.

### MATERIALS

ASTM C635 Heavy-duty main beam classification, ASTM A653 zinc-coated hot dipped galvanized steel. Exposed surfaces chemically cleansed, zinc-coated, and prefinished. Materials conform to the performance standard ASTM C645 (Standard Specification for Rigid Furring Channels for Screw Applications of Gypsum Board).

### VISUAL SELECTION

Item No.	Description	Dimensions	Rout Spacing	Hanger Spacing (Lbs./Lin. Ft.)					
				L/240	L/240	L/240	L/360	L/360	L/360
<b>Drywall Main Beams – Imperial (Red Numbers are Fire Guard Items)**</b>				<b>2 Ft.</b>	<b>3 Ft.</b>	<b>4 Ft.</b>	<b>2 Ft.</b>	<b>3 Ft.</b>	<b>4 Ft.</b>
<b>HD8906</b> <b>HD8906HRC</b> <b>HD8906G90</b> <b>HD8906IIC</b>	1-1/2" 12' HD Drywall Main Beam (For Type F Light Fixtures)	144 x 1-1/2 x 1-11/16"	54 routs – starting 2-1/4" from each end†	143.0	57.3	28.14	95.5	43.19	18.66
<b>HD890610</b>	1-1/2" 10' HD Drywall Main Beam (For Type F Light Fixtures)	120 x 1-1/2 x 1-11/16"	45 routs – starting 2-1/4" from each end†	143.0	57.3	28.14	95.5	43.19	18.66
<b>SP135</b>	1-1/2" 135" HD Stucco Main Beam G90	135 x 1-1/2 x 1-11/16"	13.5" O.C.	139.85	52.59	28.71	–	43.19	18.66
<b>Drywall Main Beams – Metric</b>				<b>600mm</b>	<b>900mm</b>	<b>1200mm</b>	<b>600mm</b>	<b>900mm</b>	<b>1200mm</b>
<b>HD7940</b>	43mm 3600mm HD Drywall Main Beam	3600 x 38 x 42.8mm	200mm O.C.	150.0	68.3	29.34	100.0	45.35	19.56
<b>7940G</b>	43mm 3600mm HD Drywall Main Beam	3600 x 38 x 35mm	150mm O.C. – starting 75mm from each end†	114.0	51.92	22.40	76.39	34.61	14.93
Item No.	Description	Dimensions	Rout Spacing	Load Total Data (Lbs./Lin. Ft.)		Load Total Data (Kg./Lin. M.)			
				L/240	L/360	L/240	L/360		
<b>Drywall Cross Tees – Imperial (Red Numbers are Fire Guard Items)**</b>				<b>6.87 @ 6'</b>	<b>4.58 @ 6'</b>				
<b>XL8965</b> <b>XL8965HRC</b>	1-1/2" 6' Drywall Cross Tee	72 x 1-1/2 x 1-1/2"	6 routs – starting 24" from each end†						
<b>XL8947P</b>	1-1/2" 50" Drywall Cross Tee	50 x 1-1/2 x 1-1/2"	8 routs – starting 10" from each end†	19.5 @ 50"	12.79 @ 50"				
<b>XL8945P</b> <b>XL8945PHRC</b>	1-1/2" 4' Drywall Cross Tee	48 x 1-1/2 x 1-1/2"	9 routs – center rout and starting 10" from each end†	22.5 @ 4'	14.27 @ 4'				
<b>XL8940</b>	1-1/2" 40" Drywall Cross Tee	40 x 1-1/2 x 1-1/2"	1 rout – center of tee	36.22 @ 40"	24.15 @ 40"				
<b>XL7936G90</b>	1-1/2" 3' Drywall Cross Tee	36 x 1-1/2 x 1-1/2"	none	50.0 @ 3'	31.33 @ 3'				
<b>XL8926</b>	1-1/2" 2' Drywall Cross Tee	24 x 1-1/2 x 1-1/2"	3 routs – center rout and 10" from each end†	158.0 @ 2'	90.25 @ 2'				
<b>Drywall Cross Tees – Metric</b>				<b>10.25 @ 6'</b>	<b>6.84 @ 6'</b>	<b>15.15 @ 1600mm</b>	<b>10.18 @ 1600mm</b>		
<b>XL7961</b>	38mm 1600mm Drywall Cross Tee (6')	1600 x 38 x 36mm	800mm center of tee						
<b>XL7930</b>	38mm 1200mm Drywall Cross Tee (4')	1200 x 38 x 38mm	450mm, 600mm, 750mm	22.4 @ 4'	14.93 @ 4'	33.33 @ 1200mm	22.22 @ 1200mm		
<b>XL7925</b>	38mm 900mm Drywall Cross Tee (3')	900 x 38 x 38mm	none	51.92 @ 3'	34.61 @ 3'	77.26 @ 900mm	51.51 @ 900mm		
<b>XL7920</b>	38mm 600mm Drywall Cross Tee (2')	600 x 38 x 38mm	none	114.59 @ 2'	76.39 @ 2'	170.52 @ 600mm	113.68 @ 600mm		

\* NOTE: All load test data based on flat installation per ASTM C635.

\*\* For fire-rated assemblies, use Type C gypsum board as noted in the UL® fire-rated assembly designs.

† Type F fixture compatible

ASTM Class  
HD - Heavy-duty  
ID - Intermediate-duty  
LD - Light-duty

TechLine 877 276-7876

armstrongceilings.com/drywall



# DRYWALL/STUCCO/PLASTER – Flat Ceilings

## Suspension Systems

### VISUAL SELECTION

Item Number	Face Flange	Description	Dimensions (Inches)	Packaging Pcs.	Lin. Ft.
<b>Moldings</b>					
7858	15/16"	12' Reverse angle molding	144 x 1-9/16 x 15/16"	20	240
LAM12	1-1/4"	12' Nominal locking angle molding, locking tabs 8" O.C, starting 4" from each end	144 x 1-1/4 x 1-1/4"	10	240
LAM12HRC	1-1/4"	12' Nominal locking angle molding, locking tabs 8" O.C, starting 4" from each end	144 x 1-1/4 x 1-1/4"	10	240
<b>new</b> LAM151220E	1-1/2"	12' Locking Angle Molding, locking tabs 8" O.C. 22 Gauge (.028" metal thickness)	144 x 1-1/2 x 1-1/2"	10	120
KAM10	1-1/4"	10' Knurled Angle Molding – (.018 metal thickness)	120 x 1-1/4 x 1-1/4"	10	100
KAM12	1-1/4"	12' Knurled Angle Molding – (.018 metal thickness)	144 x 1-1/4 x 1-1/4"	10	120
KAM12G90	1-1/4"	12' Knurled Angle Molding – G90 galvanized steel coating (.018 metal thickness)	144 x 1-1/4 x 1-1/4"	10	120
KAM12HRC	1-1/4"	12' Knurled Angle Molding – High Recycled Content (.018 metal thickness)	144 x 1-1/4 x 1-1/4"	10	120
KAM1510	1-1/2"	10' Knurled Angle Molding – (.018 metal thickness)	120 x 1-1/2 x 1-1/2"	10	100
KAM1512	1-1/2"	12' Knurled Angle Molding – (.018 metal thickness)	144 x 1-1/2 x 1-1/2"	10	120
KAM151020E	1-1/2"	10' Knurled Angle Molding – (.028 metal thickness)	120 x 1-1/2 x 1-1/2"	10	100
KAM151220E	1-1/2"	12' Knurled Angle Molding – (.028 metal thickness)	144 x 1-1/2 x 1-1/2"	10	120
KAM151020	1-1/2"	10' Knurled Angle Molding – (.033 metal thickness)	120 x 1-1/2 x 1-1/2"	10	100
KAM151020G90	1-1/2"	10' Knurled Angle Molding – G90 galvanized steel coating (.033 metal thickness)	120 x 1-1/2 x 1-1/2"	10	100
KAM21025	2"	10' Knurled Angle Molding – (.018 metal thickness)	120 x 2 x 2"	10	100
KAM21020EQ	2"	10' Knurled Angle Molding – (.028 metal thickness)	120 x 2 x 2"	10	100
KAM21020	2"	10' Knurled Angle Molding – (.033 metal thickness)	120 x 2 x 2"	10	100
<b>new</b> SC151220EQ	1-1/2"	12' x 1.5" SimpleCurve™ Knurled Angle Molding – (.028" metal thickness)	148 x 1-1/2 x 1-1/2"	10	124
<b>new</b> SC151225	1-1/2"	12' x 1.5" SimpleCurve™ Knurled Angle Molding – (.018" metal thickness)	148 x 1-1/2 x 1-1/2"	10	124
<b>new</b> SC21220EQ	2"	12' x 2" SimpleCurve™ Knurled Angle Molding – (.028" metal thickness)	148 x 2 x 2"	10	124
<b>new</b> SC21225	2"	12' x 2" SimpleCurve™ Knurled Angle Molding – (.018" metal thickness)	148 x 2 x 2"	10	124

NOTE: .018" metal thickness meets ASTM C645 for framing

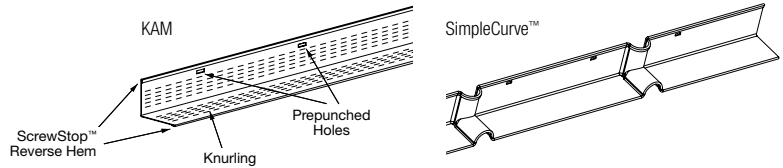
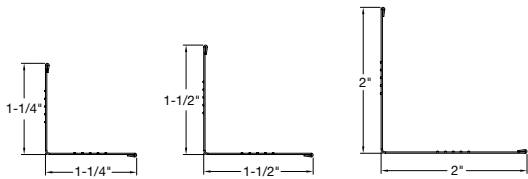

### DRYWALL LINEAR LIGHTING

Item No. *	Description	Fixture Length
□ DGSLLTK24	2' Linear Light Trim Kit	24" x 4"
□ DGSLLTK30	2' – 6" Linear Light Trim Kit	30" x 4"
□ DGSLLTK48	4' Linear Light Trim Kit	48" x 4"
□ DGSLLTK60	5' Linear Light Trim Kit	60" x 4"
□ DGSLLTK72	6' Linear Light Trim Kit	72" x 4"
□ DGSLLTK90	7' – 6" Linear Light Trim Kit	90" x 4"
□ DGSLLTK96	8' Linear Light Trim Kit	96" x 4"
□ DGSLLTK120	10' Linear Light Trim Kit	120" x 4"
□ DGSLLTKCON	10' Continuous Linear Light Trim Kit	10'

NOTE: Linear Light Trim Kits designed to work with 5/8" drywall

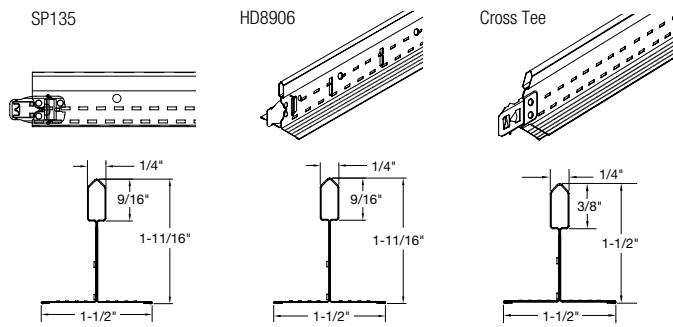
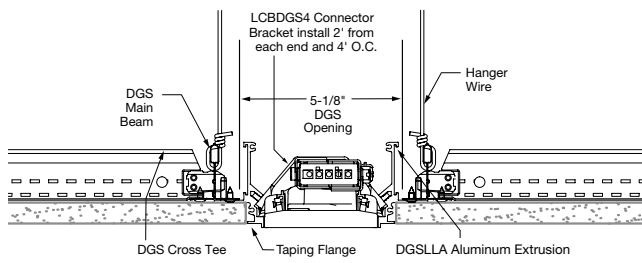

### SEISMIC PERFORMANCE

Seismic loading: ICC Evaluation Service, Inc., ESR-1289  
2009 & 2006 International Building Code  
1997 Uniform Building Code, Continuous Membrane, One Level;  
Per Section 25.210. Consult local code for requirement.

#### Main Beams

	Minimum Lbs. To Pull Out Compression/Tension
HD8906/HD890610 / HD8906HRC	332.3
HD8906IIC	332.3

#### Cross Tees

	Minimum Lbs. To Pull Out Compression/Tension
XL7918, XL8926, XL8925, XL7936G90, XL8945PHRC, XL8945P, XL8947P, XL8965HRC	380.1

### ICC Reports

For areas under ICC jurisdiction, see ICC evaluation report number ESR-1289 for allowable values and/or conditions of use concerning the suspension system components listed on this page. The report is subject to reexamination, revisions, and possible cancellation.

For fixture weight and UL listings, see Drywall Grid Systems for Flat Applications Technical Guide BPCS-3539.